

ABSOLUTAIRE, INC.
GENERAL INSTALLATION INSTRUCTIONS
DIRECT-FIRED GAS HEATING AND MAKE-UP AIR UNITS

The following recommendations are not intended to replace or void any requirements of federal, state or local codes having jurisdiction. All local authorities having jurisdiction should be consulted before installation is made. The heater should be installed and piped in accordance with the requirements of the National Fuel Gas Code, NFPA 54, and all wiring must be in accordance with the National Electrical Code, NFPA 70 current edition.

Inspect the unit for visible damage. The unit was thoroughly inspected before leaving the factory, and the carrier has accepted and signed for it. Any damage or irregularities should be noted at the time of delivery and immediately reported to the delivery carrier. Request a written inspection report from the Claims Inspector to substantiate any necessary claim. File the claim with the delivery carrier, not with AbsolutAire, Inc.

Further inspect the unit as follows:

- A) Unlatch and open Unit Access Doors. Inspect for internal damage.
- B) Remove and inspect all loose-shipped items, including remote mount control panel. Make certain all items are undamaged.

If questions or complications should arise regarding the application or installation of the AbsolutAire Air Handling System, that cannot be solved by using these instructions, our Maintenance Guidelines, or the Troubleshooting Guide, please feel free to contact us at (800) 804-4000.

It is the responsibility of the installing contractor to see that the unit is installed within the manufacturers design parameters, as stated on the rating plate, and that the start-up procedure specified by the manufacturer is followed. Failure to comply may void our warranty and/or the component manufacturer's warranty.

INSTALLATION

Inspect the blower wheels, shaft and motor for any shipping blocks which must be removed before operation.

ROOFTOP/CURB MOUNTED

For a unit that discharges downward through a curb, locate the required opening for connecting ductwork. Cut through roof deck for connection of duct to blower discharge. Allow adequate, at least one inch, clearance on all sides between ductwork and decking material. Position the curb on the roof in relation to the roof penetration, as shown on the blueprint. Secure the curb to the structural members. The curb may now be flashed into the roof. Roof top, down discharge units are provided with a skirt that is larger than the curb on all sides. This allows for roofing up to the top of the curb, if so desired. On applicable "AA" or "V" models, attach the furnished support legs to the intake end of unit, one on each side. The unit may now be lifted up onto the curb.

NOTE: Units which discharge down through the curb with discharge dampers must have the roof opening cut large enough to allow access to the damper motor and linkage from below the roof. The damper should be mounted and motor wired with pigtail provided before the unit is set on the curb.

NOTE: We recommend the connection of a short length of ductwork to the unit before setting on the curb to extend through the roof if minimum (1") clearance is being used around the duct.

PAD MOUNTED

For a unit designed to mount on a pad or other support and discharge horizontally, vibration isolators are recommended. A channel iron support adequate to carry the weight of the unit must be secured to the bottom of the unit, one at each end, extending at least 3" past the sides of the unit. On standard "AA" models, four vibration isolators will be used, one for each corner of the unit. On some "AA" models, and all "R" models, refer to your submittal or record drawing for size, quantity, and location of isolators. Anchor the vibration isolators to the pad. The unit may now be set down onto the isolators and bolted to them.

INDOOR/SUSPENDED

For a unit designed to be suspended within the building, hanger rods and channel iron adequate to support the weight of the unit will be required. On standard "AA" models, the channel iron must be secured to the bottom of the unit, one at each end, extending at least 3" past the sides of the unit. On some "AA" models, and all "R" models, refer to your submittal or record drawing for size, quantity, and location of channel iron and isolators. Attach the hanger rods to the building structure so they hang down to the channel extensions under the unit. Make sure the rod location does not interfere with the removal of unit access panels. Provide one suspension type vibration isolator in each hanger rod. The minimum combined ratings of the vibration isolators and suspension materials should equal the total weight of the fully assembled unit. Move the unit to its installation location. Fully assemble the unit with all included components (motorized discharge dampers, etc.) Raise the unit so that one hanger rod drops through holes in the channel extensions. Attach two nuts to hanger rods and level unit, jamb the two nuts together to prevent loosening.

The unit is now ready for piping, wiring, and connection to any required ductwork.

PIPING

A male pipe connection has been provided on outside of the unit for connection of the gas service pipe. This is the only gas connection required. Be sure the gas supply pipe is large enough to insure the proper gas volume and line pressure at the inlet of the unit, per the unit nomenclature. Gas pipe must be sized and installed in accordance with applicable codes and standards. After connection of the gas pipe, check for leaks and bleed the line.

NOTE: NFPA 54 National Fuel Gas Code requires that an approved manual gas valve be installed within six feet of the unit. We recommend use of a gas valve with a pressure tap on the inlet to measure gas supply pressure.

NOTE: An inlet gas pressure measurement must be taken to insure proper inlet gas pressure. Inlet pressure should be neither too low or too high. Check your submittal or unit nameplate for the minimum and maximum pressure requirements for your unit. If the supply gas pressure exceeds the maximum inlet supply pressure as stated on the unit rating plate, an auxiliary high pressure regulator must be installed in the incoming gas line by the contractor. The gas supply pressure must meet or exceed the minimum inlet

gas supply pressure, as stated on the unit rating plate, while the burner is under full fire. (See Start-Up Procedure to operate unit on high fire).

This heater and its gas shut-off valve must be disconnected from the gas supply piping system during any pressure testing of that system at pressures in excess of 1/2 PSI (3.5 KPA). In addition, pressure testing of the gas supply piping system at pressures at or below 1/2 PSI (3.5 KPA) requires isolation from the heater by closing its individual manual shut-off valve.

WIRING *(Refer to unit mechanical drawing for location of electrical rough in).*

All electrical wiring must be in accordance with applicable codes and standards. See the electrical diagram on the unit door or in the service manual before attempting any wiring. Refer to the unit rating plate for required incoming voltage and phase. Check for concurrence with voltage and phase shown on the wiring diagram.

Refer to wiring diagram for numbers of wires needed for main power connection and remote control wiring. Field wiring is shown with dashed lines.

WARNING!!! - Spark testing or shorting of control wires by any means will render the control transformer inoperative. **DO NOT** allow this to happen as it **IS NOT** covered under the warranty.

We recommend that the wires for the control circuit be routed through the conduit provided with the main electrical service to the equipment. This procedure is provided for in Chapter 3, Article 300-3(a) of the NFPA 70 1984 National Electrical Code. It reads as follows: "Conductors of 600 volts or less shall be permitted to occupy the same equipment wiring enclosure, cable or raceway, without regard to whether the individual circuits are alternating current or direct current, where all conductors are insulated for the maximum voltage of any conductor within the enclosure, cable or raceway."

An electric disconnect switch having adequate ampacity shall be installed in accordance with Article 430 of the National Electric Code (N.E.C.), ANSI/NFPA 70. If not factory installed, please refer to the unit rating plate for voltage and ampacity requirements.

Open cover on disconnect box, connect line voltage wiring to terminal block provided. Then feed the control wiring through the conduit to the master panel. Connect color coded and/or numbered control wires to terminal strip per the wiring diagram.

NOTE: Wires for Maxitrol Series 14 and Series 44 temperature controls must be run in shielded cable. For best results, run control wiring in separate conduit if the run is over 100 feet. For longer runs see Maxitrol Installation Instructions.

DUCTWORK

Ductwork must be sized and installed in accordance with applicable codes and standards. On units mounted outdoors, it is recommended that all discharge and return air ducts be insulated to prevent condensation during the "Off" cycle in cold weather. A fresh air intake hood with bird screen and/or filters can be supplied by AbsolutAire with the heater. Our intake hood or one of a similar design is recommended.

On units mounted indoors with through the roof intake ductwork, a suitable weather resistant intake hood must be installed. Sheet metal standards should be adhered to to ensure uniform air delivery to the heater inlet. This aids in preventing moisture entrainment. When using a through the wall intake duct, an intake louver properly sized should be used, having adequate moisture baffling characteristics for the design air volume.

In lieu of an intake louver, a wall mounted intake hood with mesh screen may be used. This can be supplied by AbsolutAire. It is recommended that all intake ductwork which is exposed to the heated space be insulated.

The requirements for discharge ductwork are usually considerably less than with a conventional system, as the pressurization principle lends itself to effective air distribution. Generally, a "Splash Plate" or other method of distributing the air is all that is necessary.

SOUND CONTROL

Flexible connectors should be employed on all ductwork connections. Unit vibration isolators are recommended for suspended units and can be supplied by AbsolutAire as optional equipment.

DO NOT OPERATE UNIT FOR MORE THAN SIXTY (60) SECONDS WITHOUT ALL ACCESS DOORS CLOSED. WITH THE EXCEPTION OF THE MASTER ELECTRICAL PANEL OR GAS MANIFOLD ENCLOSURE DOORS.

Energize the system and check for unusual noises or vibrations, etc. Check the fan for proper rotation. **THIS MUST BE A VISUAL CHECK** as fans will move air even if they are running backward, but the system will not perform properly. Check the amp draw to all motors to insure it does not exceed the rated maximum current rating of the motor.

If not factory installed, a low temperature limit switch should be interlocked with this heater to prevent prolonged discharge of cold air in the event of burner lockout or shutdown.

Recirculation of room air may be hazardous in the presence of:

- *Flammable liquids, solids and gases**
- *Explosive dusts or powders**
- *Substances which become toxic when exposed to heat**

In order to reduce the chance of interior condensation, recirculation is not recommended in non-insulated buildings where outdoor temperatures fall below 32°F (0°C).

PROCEED WITH THE FIELD START-UP AND CHECK LIST

ABSOLUTAIRE, INC.

5496 North Riverview Drive

Kalamazoo, MI 49004-1595

Telephone: (800) 804-4000 Facsimile: (269) 382-5291

email: jwbudnick@absolutaire.com

ABSOLUTAIRE
MAINTENANCE GUIDELINES
DIRECT-FIRED GAS HEATERS AND MAKE-UP AIR UNITS

5496 North Riverview Drive / Kalamazoo, MI 49004
Phone (800) 804-4000 / Facsimile (269) 382-5291

Your ABSOLUTAIRE product is engineered to provide trouble-free operation.
In order to assure proper performance the following maintenance schedule is recommended.

MOTOR: Check the motor sheave set-screws and the motor slide base bolts for tightness upon initial start-up and before each heating season. The motor bearings are pre-lubricated at the factory for initial operation but should be re-lubricated (when provided with grease fittings) at six (6) month intervals. AbsolutAire recommends the use of Shell Oil Company's "Dolium R", Chevron Oil's "SRI No. 2", or Texaco "Premium RB" lubricant. Clean the grease fitting and then apply the grease with a proper grease gun. Use two full strokes for each bearing.

CAUTION: Do not over lubricate.
Keep grease clean.
Lubricate motors at standstill.
Do not mix petroleum grease with silicone grease.

BLOWER: After initial start-up, check the tightness of the fan sheave, fan hub set screws, fan bearing collar set screws, and fan bearing mounting bolts. Also when re-tensioning the v-belts, when re-lubricating the fan bearings, and before each heating season.

AA & V Model Heaters: Most units with 18" and smaller blowers are provided with pre-lubricated sealed bearings which require no additional lubrication for the life of the bearing. Some models are provided with pillow block bearings and should be lubricated annually using the following (or equivalent) grease:

ESSO Beacon 325 or Shell Alvania #3 or equivalent

R-Series Model Heaters: All R-Series fan bearings should be lubricated after the first one hundred (100) hours of operation, and re-lubricated on a quarterly basis thereafter. AbsolutAire recommends the use of the following (or equivalent) grease:

MOBIL SHC460

Clean the grease fitting and then apply the grease with a proper grease gun. Inject enough grease until a small amount shows between the seal and the bearing race.

Examine the blower wheel at six (6) month intervals for accumulation of dust and dirt on the fan blades. Any build-up must be cleaned off to maintain performance. If the accumulation is heavy, more frequent cleaning may be required.

BELTS: Due to belt stretching, adjust belt tension after the first one hundred (100) hours of operation. Check belts every three months thereafter for proper tension. Do not over tighten. Adjustment should result in a belt deflection of 3/4" to 1" for each foot of span when applying medium thumb pressure inward at the center of the span.

FILTERS: Inspect monthly until an appropriate schedule can be established, based on need. Replace or clean as necessary.

COILS: Inspect and clean the coil fins on the entering air side annually. If these inspections indicate that more frequent cleaning is required, establish a cleaning schedule accordingly. Fins should be cleaned by brushing and/or back-washing with high pressure air or water. In extreme cases the coils may have to be removed and cleaned with high pressure steam or washed with a mild alkali solution followed by a water rinse.

TRAPS AND STRAINERS: Periodic inspections of traps, inspections of check and air valves, and the replacement of worn parts are important. Strainers should be cleaned regularly.

BURNER: Prior to each heating season, a check should be made of the burner and components. Clean the igniter and flame rod and examine porcelain for cracks. Wipe the sight glass clean on the UV scanner and inspect the sight tube for spider webs, removing as necessary.

Periodic maintenance will insure continued trouble-free operation of your burner system. We recommend a yearly inspection, in advance of the heating season.

- 1) Shut the system down totally, disconnecting or locking out the power supply so there can be no accidental start-up during the inspection.
- 2) Inspect the burner carefully, including upstream and downstream sides of mixing plates as well as burner body face. Any accumulation of scale or foreign material on either side of the mixing plates should be removed with a wire brush. Check visually that no holes in the mixing plates are blocked. If any mixing plates are loose or missing fasteners, tighten/replace as necessary. Always use zinc plated or stainless fasteners.
- 3) Check burner orifices for carbon build-up and clean if necessary. Use a pin vise with a #31 drill bit for cleaning Midco natural gas burner orifices, a #45 drill bit for cleaning Midco propane (LPG) gas burner orifices, a #47 (5/64") drill bit for

Maxon NP-I burner orifices, and a #50 (1/16") drill bit for Maxon NP-II burner orifices.

DO NOT ENLARGE BURNER ORIFICES - THIS MAY AFFECT PERFORMANCE

- 4) Put the system back into operation and view the burner from the downstream side while cycling the burner through its full firing range. A good flame will be blue, with minimal yellow "fingers". The flame length in forced "high fire" should be 12-18" long. The pilot only flame should be about the size of a baseball when properly adjusted.

GAS TRAIN: An annual inspection of the gas control assembly should be made. Internal and external piping should be checked for leaks. Relief vents on gas controls should be checked for clogging.

AIR PRESSURE SWITCHES: An annual check of the tube for the air flow switch, and the entering and leaving side of building pressure switches, should be made to insure against blockage.

DAMPER AND MOTOR: Check linkage connection and/or set screws for tightness. Lubricate the damper bushings as required.

PAINTING: After unit installation, touch up any scratches caused by handling. Periodic touch-up painting should be done thereafter as needed.

GASKETS: Inspect door gasket seals annually. Replace those showing damage or deterioration.

Fan Bearing Lubrication Frequency

Under normal conditions, no relubrication is the rule. The bearing lubricant cavity is 1/3 to 1/2 filled as shipped from the factory. A lithium based grease, suitable for long term use, is sealed in the bearing making relubrication unnecessary under most operating conditions. Insert bearings are non-lubricatable. Pillow-block bearings have a grease fitting. **Never lubricate new bearings**

As a guideline with large safety margins, bearing manufacturers publish a mathematical method to calculate the service life of grease based on the bearing RPM, diameter, and load. For example, the grease service life of a 910 blower delivering 2000 CFM against 1-1/2" S.P. @ 1019 RPM is 38,000 hrs (4 years +). The grease service life in the same application but with a 1-3/16" shaft is slightly less at 35,000 (4 years). **Using larger bearings does not increase the grease service life.**

Relubrication frequency should be increased when bearings are exposed to abnormal conditions such as elevated temperatures, water, or excessive dust.

Type of Lubricant

The bearings supplied by Delhi use ESSO - Beacon 325 grease, which has lithium-soap thickening agent. When relubricating, it is important to use a compatible grease (i.e. similar thickener). **Mixing of non-compatible lubricants can cause a drastic change in the lubricant properties and may result in premature bearing failure.** Compatible lubricants are ESSO - Beacon 325 or Shell - Alvania Grease #3.

Lubrication Procedure

Disconnect and lock-out the power to the unit. Remove the belt and rotate the blower by hand while adding a small amount of grease. One to two shots from a grease gun is satisfactory. Do not over lubricate - over lubrication will cause higher operating temperatures and lead to premature failure.

Bearing Installation

Eccentric locking collar type

With the bearing positioned and mounted, slip the collar over the inner eccentric ring and rotate the collar in the direction of rotation. Insert a drift pin in the pin hole and tap in the direction of rotation to set. Tighten locking collar set screw collar firmly.

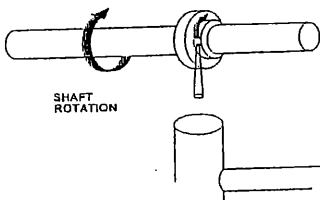

Set Screw type

The 2 Set screws located 120 deg. apart should be tightened equally. A small flat can be filed on the shaft under the set screw for added security and to facilitate future replacement by recessing the set screw burr. Follow the manufacturers torque recommendations since overtightened set screws can fracture the inner ring. Recommended torque settings are shown below:

Bearing Size	Recommended Torque IN-LB
3/4" & 1"	28
1-3/16" & 1-7/16"	37
1-11/16" & 1-15/16"	58
2-3/16"	83

INSTALLATION GUIDELINE

WHEN INSTALLING HORIZONTAL ABSOLUTAIRE EQUIPMENT ON PITCHED OR UNLEVEL ROOFS, BE SURE TO SQUARE/LEVEL THE UNIT IN BOTH THE X & Y AXIS TO INSURE PROPER UNIT OPERATION & LONGEVITY OF COMPONENTS.

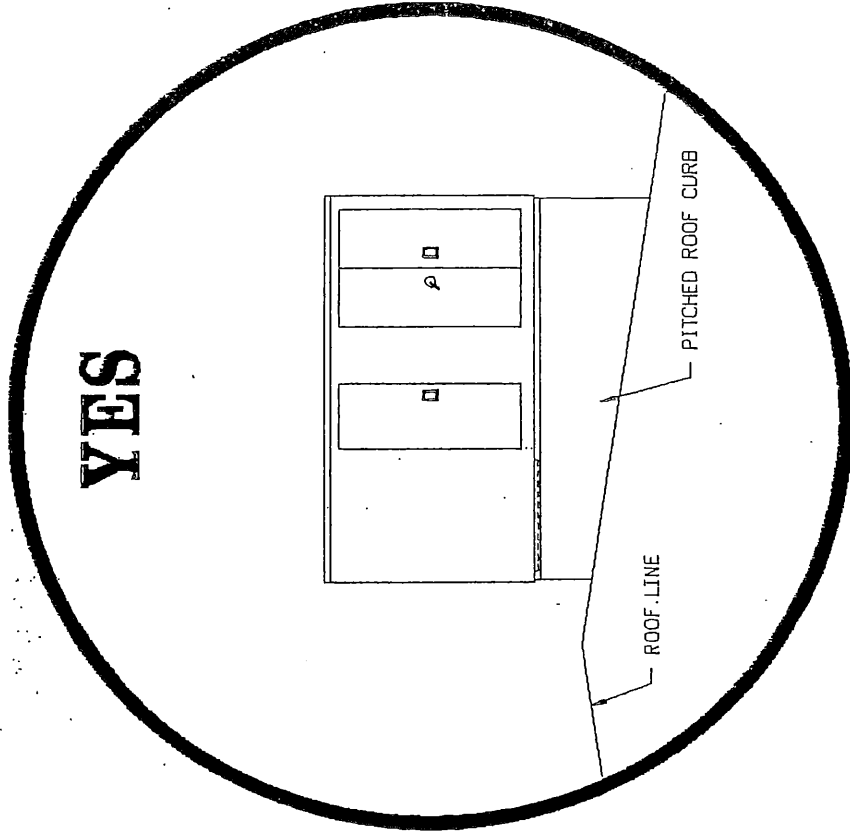
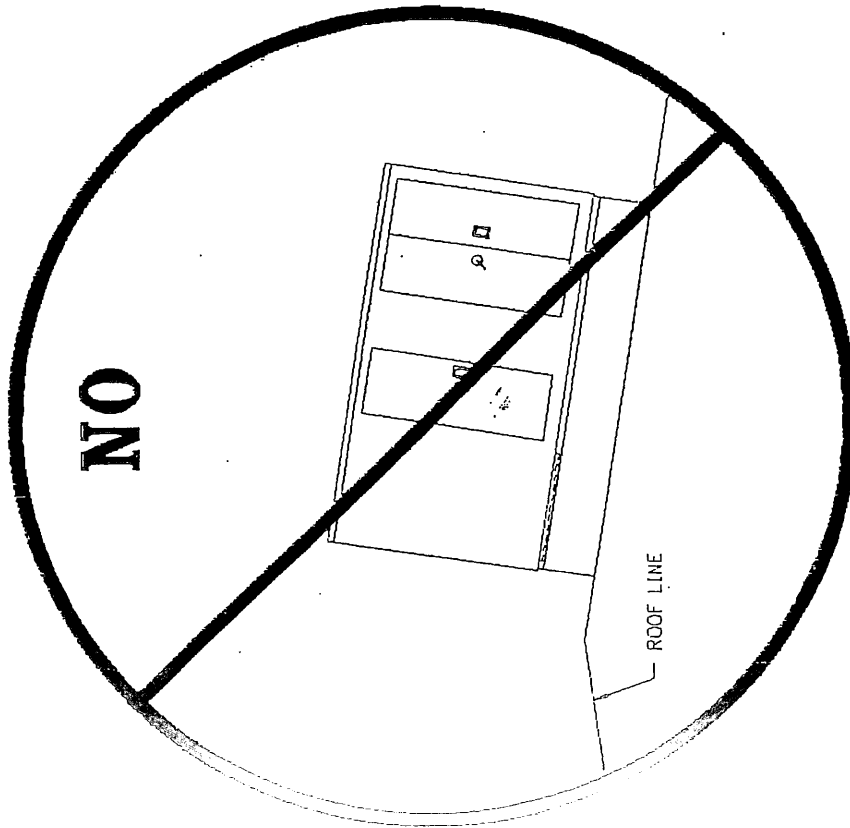

NOTES:

AbsolutAire, Inc.		5496 North Riverview Dr., Kalamazoo MI 49004	
DESC. R300 HORIZONTAL UNIT INSTALLATION GUIDELINES		REV. FILE NO.:	
SCALE NONE	DRAWN BY: AMB	DATE: 4-21-94	REV. FILE NO.:
PLOT RATIO: 1=1	CK BY: -	WO# -	LEVEL2
DRAWING FILE LOCATION: D:\HTR-LIT		AAI PART #:	
REV.	ECO#	DATE	CK BY
-	-	-	-

CAULKING THE HEATER

All field joints must be properly caulked and sealed for the heater to operate correctly.

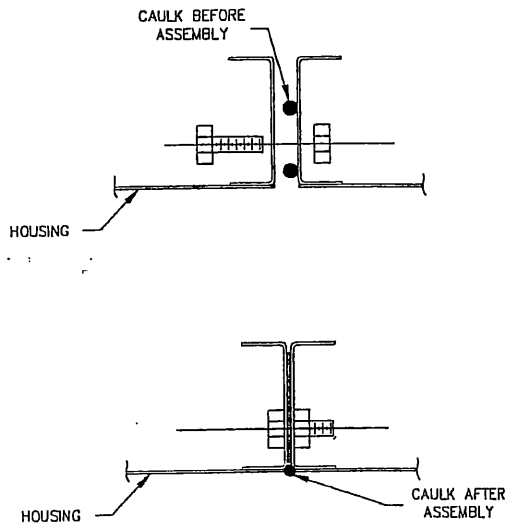

**SIDE SEAMS
CAULK JOINT**

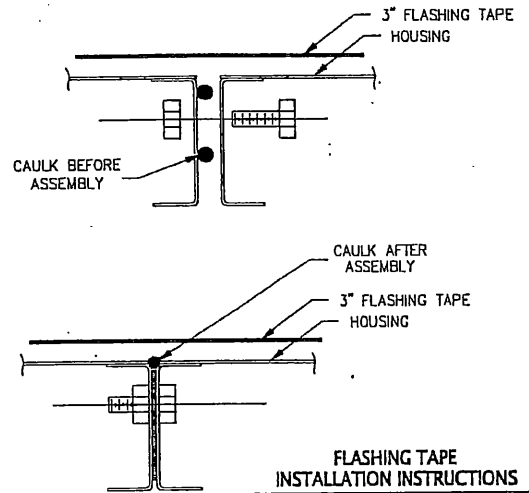

**FLASHING TAPE
INSTALLATION INSTRUCTIONS**

- 1) WIPE SURFACE CLEAN & DRY
- 2) PEEL BACKING OFF FLASHING TAPE
- 3) APPLY FLASHING TAPE FIRMLY OVER FIELD JOINT.

**ROOF SEAMS
CAULK & TAPE JOINT**

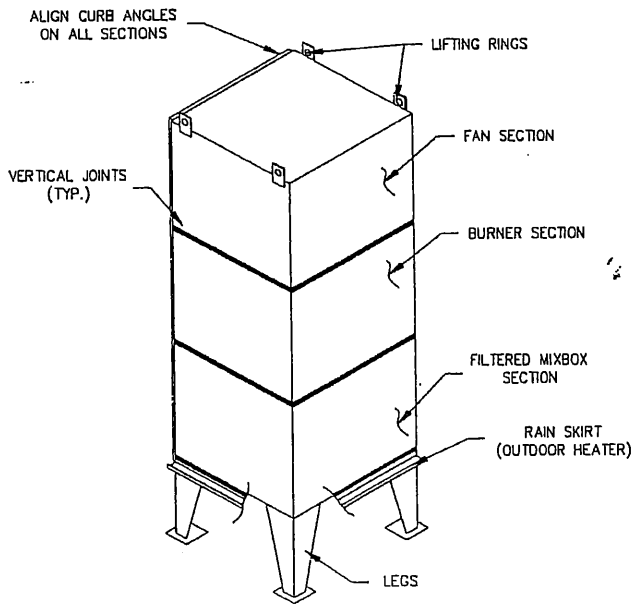

UPRIGHT MODEL

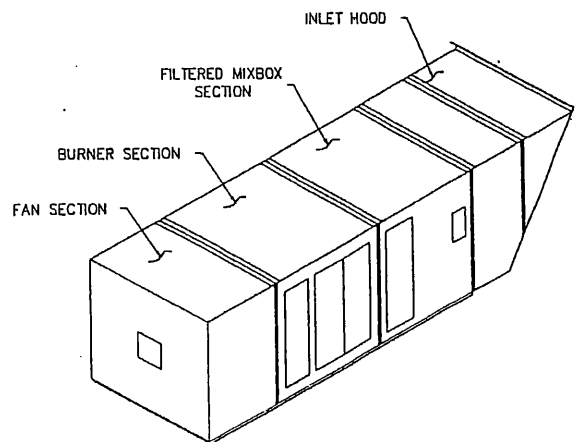

SEALING INSTRUCTIONS

- ≡ COVER WITH 3" FLASHING TAPE
- SEAL WITH A HEAVY BEAD OF CAULK

HORIZONTAL MODEL

PLEASE NOTE: ALL HORIZONTAL, VERTICAL & ROOF JOINTS MUST BE HEAVILY CAULKED PRIOR TO AND AFTER ASSEMBLY

INSTALLATION TECHNICIAN

PLEASE READ BEFORE INSTALLING
ANY ABSOLUTAIRE PRODUCTS

APPROXIMATE RIGGING WEIGHTS								
MODEL NO.	BASE UNIT	O.A. FILTER	FILTERED MIXBOX	INLET HOOD	FILTERED INLET HOOD	LOUVERED INLET PLENUM	UPRIGHT O.A. PLENUM BASE	UPRIGHT SERV. PLATFORM
AA1700	350	75	CF	50	50	CF	125	250
AA3000	500	125	200	50	75	CF	150	250
AA1	800	150	275	75	100	CF	225	300
AA2	800	150	275	75	100	CF	225	300
AA3	975	200	375	75	100	CF	325	325
AA4	1,375	250	475	150	300	CF	450	375
AA5	2,325	350	650	325	500	CF	600	400
AA6	2,600	350	650	325	500	CF	600	400
AA7	4,125	500	1,050	450	725	CF	1,000	475
AA8	4,300	500	1,050	450	725	CF	1,000	475
R327	2,500	450	625	375	500	950	500	375
R330 - R336	2,750	525	825	450	625	1,300	700	325
R340	4,125	625	1,000	500	650	1,600	850	375
R344 - R349	4,500	750	1,250	625	800	2,050	1,150	500
R354	6,125	900	1,500	750	1,050	2,550	1,400	525
R360	6,550	1,000	1,750	850	1,125	3,000	1,600	550
*R366	4,400/3,600	1,125	2,050	900	1,200	3,500	2,000	600
*R373	4,900/4,100	1,300	2,400	1,000	1,400	4,000	2,250	650
*R380	7,600/5,900	1,500	2,600	1,200	1,600	4,550	2,500	700
*R389	7,900/6,100	1,600	2,900	1,250	1,750	5,700	2,800	725
*(2) PIECE HEATERS	FAN/BURNER							

CF = CONSULT FACTORY FOR WEIGHTS

RIGGING TIPS & GUIDELINES

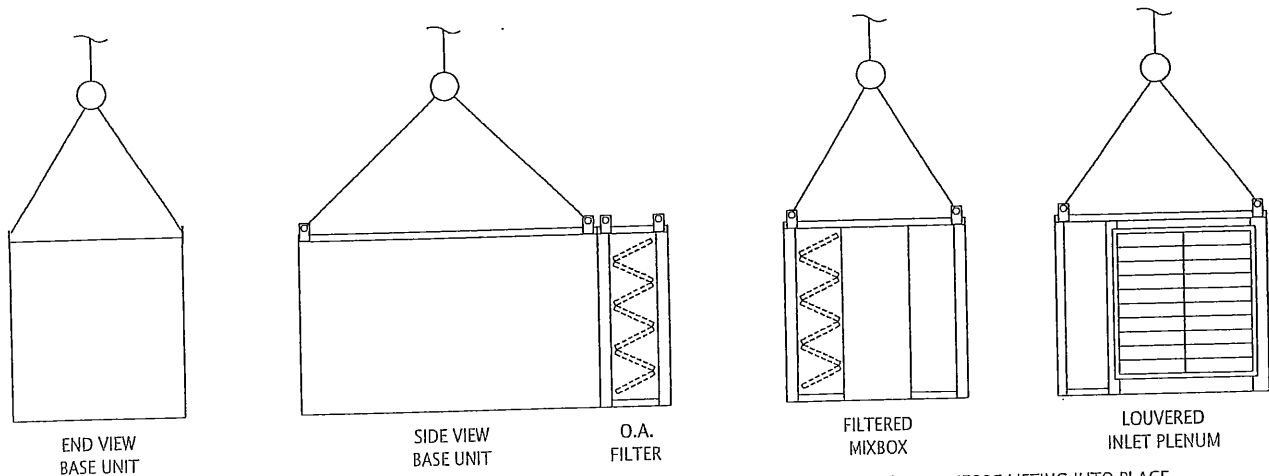

- NOTE: (1) O.A. FILTER SECTION, INLET HOOD & SERVICE PLATFORMS SHOULD BE FINAL ASSEMBLED TO "BASE" UNIT BEFORE LIFTING INTO PLACE.
 (2) FILTERED MIXBOX, LOUVERED INLET PLENUM, DISCHARGE HEAD & ROOF CURB ARE RIGGED SEPARATE FROM THE "BASE UNIT" AND ASSEMBLED TO THE UNIT, ONCE IN PLACE.
 (3) TWO-PIECE "BASE UNIT" MODELS SHOULD BE RIGGED SEPARATELY AND ASSEMBLED IN PLACE.

ALL WEIGHTS ARE FOR STANDARD CONSTRUCTION -- CONSULT FACTORY FOR SPECIALS.

T:\HRTR-LIT\LIT-14\10000066 5-21-07

INSTALLATION TECHNICIAN

PLEASE READ BEFORE INSTALLING

APPROXIMATE RIGGING WEIGHTS										
MATERIAL MODEL NO.	BASE UNIT		SIDE ACCESS FILTER SECTION		INLET HOOD		FILTERED INLET HOOD		INLET HOOD w/LOUVER	
	ALUM.	*GALV.	ALUM.	*GALV.	ALUM.	*GALV.	ALUM.	*GALV.	ALUM.	*GALV.
V1	255	285	40	55	30	35	35	40	45	50
V2	335	385	50	70	40	50	50	60	65	75
V3	490	560	75	100	50	65	60	75	90	105
V4	590	715	85	120	55	75	70	90	100	120
V5	790	940	100	150	60	100	80	120	130	170

* IF UNIT IS CONSTRUCTED OF ALUMINIZED STEEL, USE SAME WEIGHT AS GALV.

RIGGING TIPS & GUIDELINES

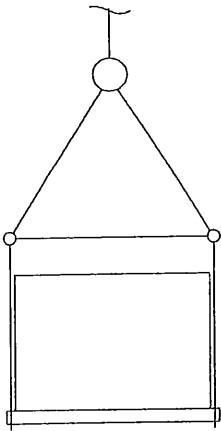

END VIEW
BASE UNIT

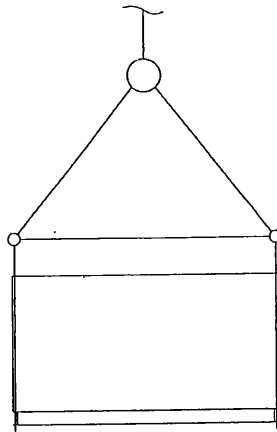

SIDE VIEW
BASE UNIT

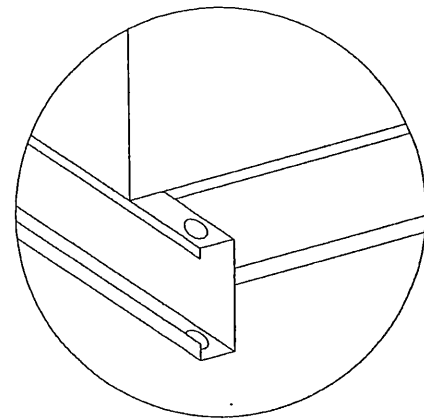

CHANNEL
DETAIL

WARNING

If this unit was not provided with an integral freeze protection system, a low temperature limit control should be installed (if freeze protection is needed in the event of burner shut-down).

INSTALLATION GUIDELINE

WHEN INSTALLING UPRIGHT ABSOLUTAIRE EQUIPMENT ON WARPED, UNLEVEL, OR RAISED SURFACES, BE SURE TO SQUARE/LEVEL THE UNIT IN BOTH THE X & Y AXIS TO INSURE PROPER UNIT OPERATION & LONGEVITY OF COMPONENTS.

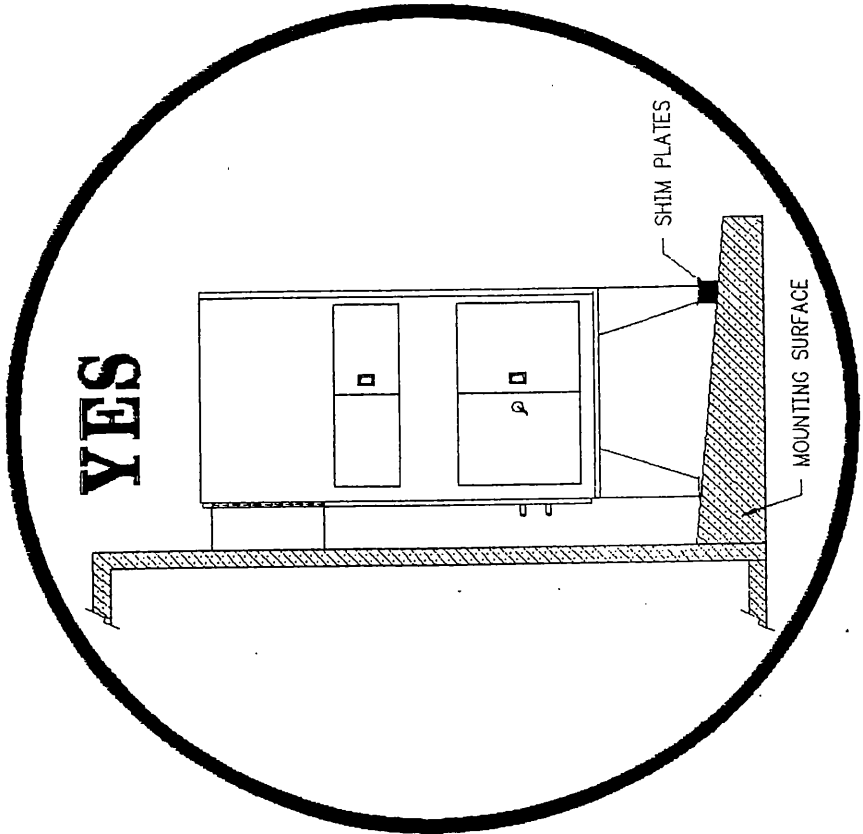
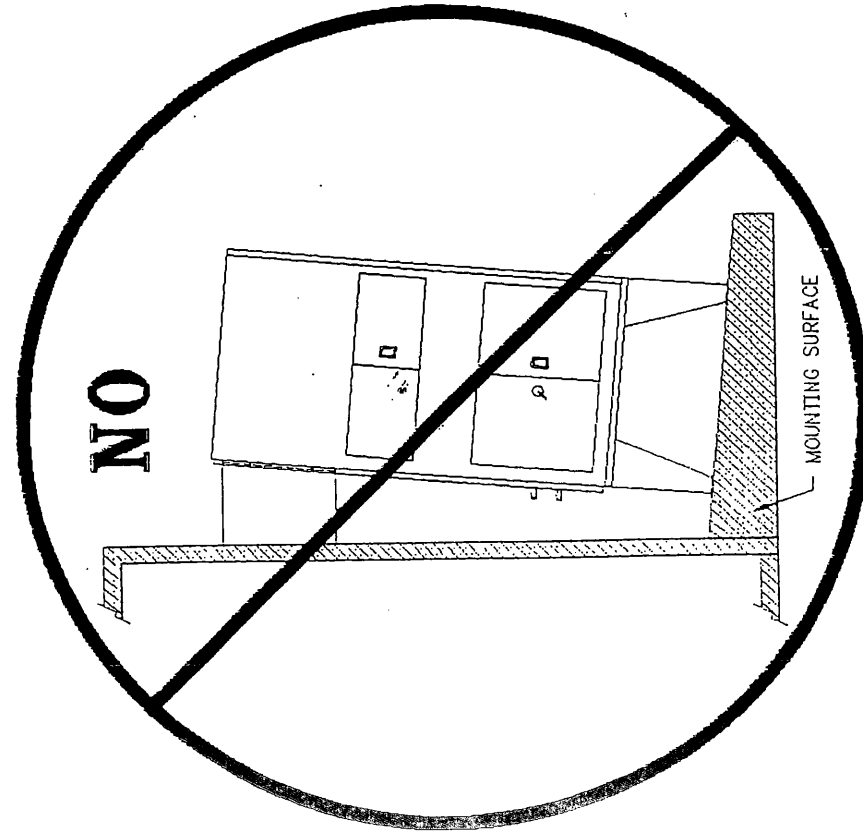

NOTES:

Absolut Air, Inc.
5496 North Riverview Dr., Kalamazoo MI 49004

DESC. R300 INSTALLATION GUIDELINES
SCALE NONE DRAWN BY: AMB DATE: 4-21-94 REV. FILE NO.:
PLOT RATIO: 1=1 CK BY: - WO# - - LEVEL 1

REV.	ECO#	DATE	CK BY

D:\HR-LIT

DRAWING FILE LOCATION